



**RA/RA-UC**

# **RADIAL RIVETING MACHINES**

# RADIAL RIVETING MACHINES

## NEW AGME RIVETING MACHINES WITH THE LATEST TECHNOLOGY

The new AGME RA radial riveting machines are highly efficient machines that integrate numerous improvements and solve most assembly needs: from forming small rivets in fragile parts to achieving large heads in different shapes.

With a more current and innovative design, RA riveting machines incorporate a significant advance in the concepts of durability, ergonomics and respect for the environment. Thanks to a working system based on a planetary movement, the fourth generation of AGME riveting machines achieves **perfect riveted joints** with very little effort by progressive forming with an adequate fibers' distribution.

Additionally, their **modular design** provides multiple possibilities which deliver great versatility, efficiency and an important cost reduction.



/RA-16 with AC-1

### TECHNICAL FEATURES

MODEL	RA-6	RA-12	RA-14	RA-16	RA-18	RA-20
Max final diameter 40 Kg/mm <sup>2</sup>	6 mm	12 mm	14 mm	16 mm	18 mm	20 mm
Adjustable riveting stroke	5-40 mm	5-40 mm	5-50 mm	5-50 mm	5-50 mm	5-50 mm
Max. air pressure	6 bar	6 bar	6 bar	-	6 bar	-
Max. hydraulic pressure	-	-	-	40 bar	-	65 bar
Axial force	475 daN	1.265 daN	1.880 daN	2.500 daN	3.240 daN	4.000 daN
Adjustable riveting time	0-5 sec	0-5 sec	0-5 sec	0-5 sec	0-5 sec	0-5 sec
Power circuit	230/400v 50/60 Hz	230/400v 50/60 Hz	230/400v 50/60 Hz	230/400v 50/60 Hz	230/400v 50/60 Hz	230/400v 50/60 Hz
Installed Power	0.4 kW	0.7 kW	1.6 kW	2.8 kW	1.6 kW	2.8 kW
Control Circuit	24V DC	24V DC	24V DC	24V DC	24V DC	24V DC
Two hand safety control	Included	Included	Included	Included	Included	Included
Operation control in 9 languages	Included	Included	Included	Included	Included	Included
Parts counters	Included	Included	Included	Included	Included	Included
Stroke centesimal adjustment	Included	Included	Included	Included	Included	Included
Weight	155 Kg	160 Kg	285 kg	290 kg	300 Kg	295 kg

\* The RA-4 and RA-30 are built on customer's request



AGME, your partner for Automatic Assembly Equipment!

## PNEUMATIC

### / DIMENSIONS

MODEL	RA-6	RA-12	RA-14	RA-18
A	713-928	794-964	1015-1225	1015-1225
B	85-300	60-230	60-270	60-270
C	5-40	5-40	5-50	5-50
D	Ø74	Ø90	Ø105	Ø125
E	170	170	180	200
F	120	120	125	115
G	100	100	125	125
H	470	470	525	525
I	696	696	713	723
J	40	40	30	30
K	320	320	350	350
L	135	135	130	130

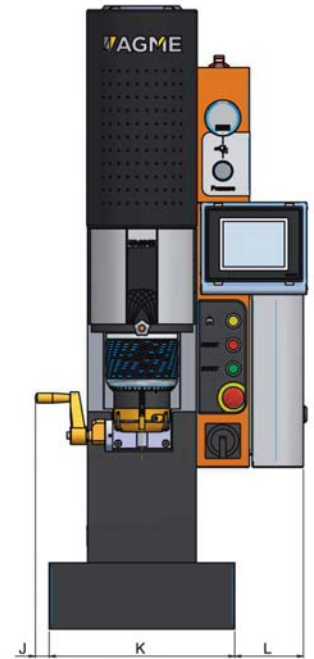
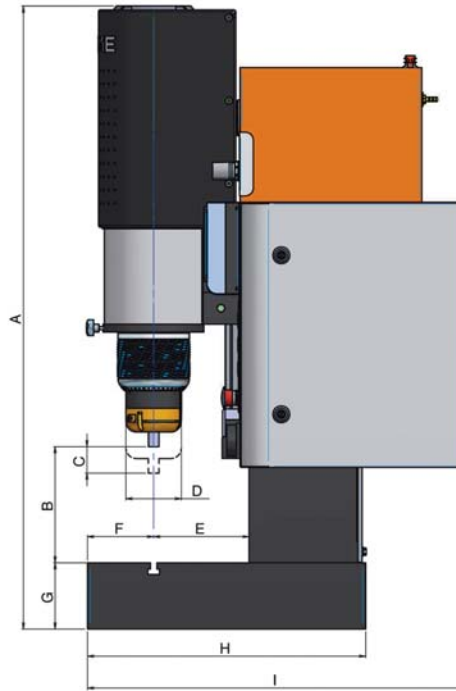

## HYDRAULIC

### / DIMENSIONS

MODEL	RA-16	RA-20
A	1020-1230	1020-1230
B	60-270	60-270
C	5-50	5-50
D	Ø105	Ø125
E	180	180
F	125	125
G	125	125
H	525	525
I	845	845
J	30	30
K	350	350
L	130	130

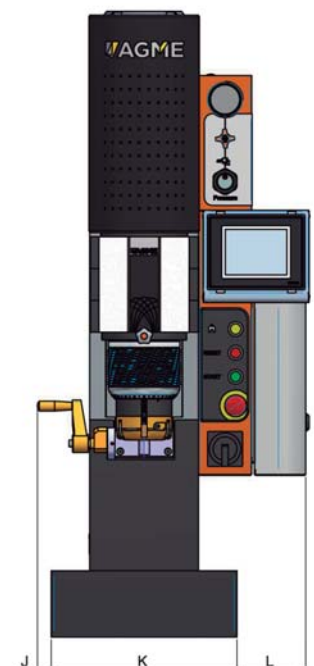
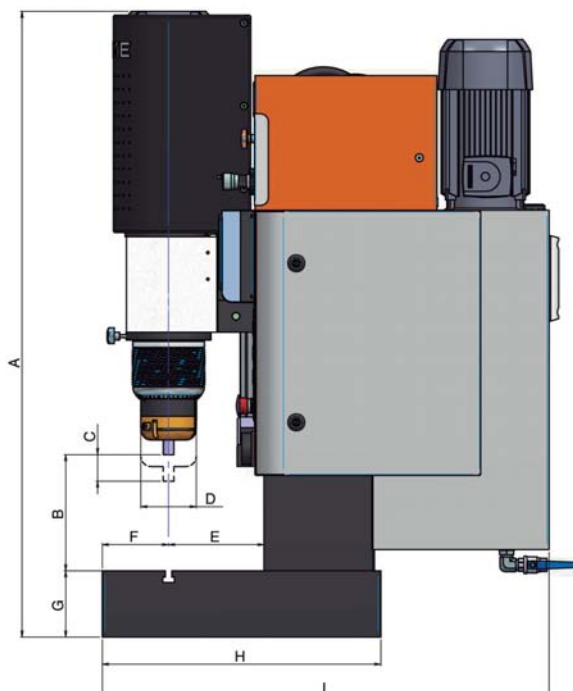

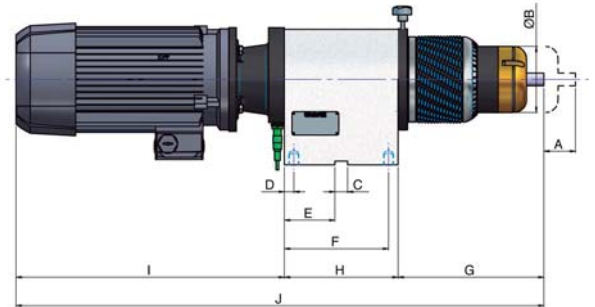
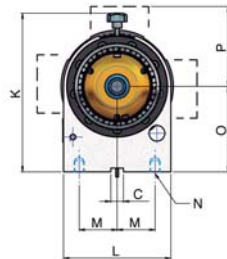

## /RA-12 UC

AGME **riveting head** units are designed to be integrated into special machines by engineering firms or special purpose machine manufacturers.

The riveting heads are also developed to work in any position, **horizontal, vertical or inclined**, and offer great flexibility.

## / DIMENSIONS

MODEL	RA-6 UC	RA-12 UC	RA-14 UC	RA-16 UC	RA-18 UC	RA-20 UC
A	5-40	5-40	5-50	5-50	5-50	5-50
B	73,5	89,5	105	105	125	125
C	20	20	20	20	20	20
D	10	7,5	15	15	15	15
E	50	72,5	80	80	80	80
F	110	157,5	165	165	165	165
G	155	158,5	231	231	231	231
H	120	165	180	180	180	180
I	271	310,5	420	425	420	425
J	546	634	831	836	831	836
K	210	235	262	250,5	300	250.5
L	135	160	195	170	235	170
M	57,5	60	60	60	60	60
N	M10x20	M10x20	M12x30	M16x30	M16x30	M16x30
O	110	125	135	135	155	135
P	100	121	126	126	126	126

## / TECHNICAL FEATURES

MODEL	RA-6 UC	RA-12 UC	RA-14 UC	RA-16 UC	RA-18 UC	RA-20 UC
Max. final diameter 40 Kg/mm <sup>2</sup>	6 mm	12 mm	14 mm	16 mm	18 mm	20 mm
Adjustable riveting stroke	5-40 mm	5-40 mm	5-50 mm	5-50 mm	5-50 mm	5-50 mm
Max. air pressure	6 bar	6 bar	6 bar	-	6 bar	-
Max. hydraulic pressure	-	-	-	40 bar	-	65 bar
Axial force	475 daN	1.265 daN	1.880 daN	2.500 daN	3.240 daN	4.000 daN
Motor power	0,25 kW	0,55 kW	1,5 kW	1,5 kW	1,5 kW	1,5 kW
Stroke centesimal adjustment	Included	Included	Included	Included	Included	Included
Weight	20 Kg	31 Kg	60 Kg	72 Kg	72 Kg	77 Kg

\* The RA-4 UC and RA-30 UC are built on customer's request





# RIVETING

TECHNOLOGY



## / CONTROLS AND SOFTWARE

The management of riveting can be completed through different efficient, agile and easy to use control systems:

### C-400 standard control

This control is the basic equipment of all riveting machines. Among other parameters, it can adjust and visualize the riveting time, 5 preselection counters, safety time and shift-based counters.



### AC1 and AC2 Quality Assurance Systems

They are more advanced systems that control the pressure and position during the riveting process. They detect and evaluate the following parameters, selecting Ok and NOK parts:

- Contact and final positions
- Riveting distance
- Riveting pressure
- Riveted head height
- Riveting time

Thanks to these parameters, the rivet presence and initial length, as well as the riveting tool wear, can also be detected.

**The AC1 quality assurance system** is based on the absolute measure of the riveting head position. It measures the riveting stroke from the machine resting position.

**The AC2 quality assurance system** includes a floating device that holds the components to be riveted and determines the reference surface for measurement of the riveting stroke.



AC System

## / APPLICATIONS

The RA radial riveting machines have a large number of possible applications in cold forming processes for rigid or mobile joining of components with rivets. AGME integrates its **in-house riveting technology** by adapting our

standard riveting machines to the technical specifications of every production process and application, in terms of dimensions and controls, as well as special fixtures, riveting tools and other accessories.

Our **custom riveting solutions** are used by highly demanding industries such as:

- **Automotive components:** manufacturers of seats, ball joints, hinges, window regulators, hand brakes, etc.
- **Other industries:** hardware industry, electrical, household appliances and general industry.



This leadership in riveting technology is based on our **extensive experience** and expertise in developing riveting solutions, our **R+D+I activity** in pursuit of excellence and an important **international presence**. Our extensive distribution and technical service network enable full support at all times.



# AGME WORLDWIDE

## Global presence

### EUROPE

Austria  
Belgium  
Czech Republic  
France  
Germany  
Great Britain  
Hungary  
Italy  
Netherlands  
Poland  
Portugal  
Romania  
Slovakia  
Slovenija  
Turkey

### ASIA

China  
India  
Israel

### AMERICA

Brazil  
Canada  
Mexico  
USA

### AFRICA

Egypto

## National distributors

### EUSKADI

Iker Beitia  
T: 617 345 848  
ikerbeitia@euskalnet.net

### CATALUÑA

Industrias Galan  
Fluviá, 79  
08019 Barcelona  
T: 932 174 808  
F: 932 178 555  
M: 607 263 124  
egalan@iegalan.com

### MADRID - CENTRAL AREA

Ingeniería y  
Gestión Industrial, S.L.  
C/ Sagunto, 11, bajo ext. izqda  
28010 Madrid  
T: 91 591 21 07  
F: 91 447 12 13  
M: 629 380 090  
c.carabajal@ingegest.com

### NAVARRA - LA RIOJA

Javier Onieva  
M: 679 965 334  
j.onieva@agme.net

Contact details on  
[www.agme.net](http://www.agme.net)



Automated assembly solutions

### HEADQUARTERS

**Aguirregomezcorta y Mendicute S.A.**

Apdo. 263. Apalategi, 7  
20600 Eibar. Gipuzkoa. Spain  
T:+34 943 121 608  
F:+34 943 121 572  
[agme@agme.net](mailto:agme@agme.net)  
[www.agme.net](http://www.agme.net)

